

FEATURES

- Linear current output: 1 $\mu\text{A}/\text{K}$**
- Wide temperature range: -55°C to $+150^{\circ}\text{C}$**
- Probe compatible ceramic sensor package**
- 2-terminal device: voltage in/current out**
- Laser trimmed to $\pm 0.5^{\circ}\text{C}$ calibration accuracy (AD590M)**
- Excellent linearity: $\pm 0.3^{\circ}\text{C}$ over full range (AD590M)**
- Wide power supply range: 4 V to 30 V**
- Sensor isolation from case**
- Low cost**

GENERAL DESCRIPTION

The AD590 is a 2-terminal integrated circuit temperature transducer that produces an output current proportional to absolute temperature. For supply voltages between 4 V and 30 V the device acts as a high-impedance, constant current regulator passing 1 $\mu\text{A}/\text{K}$. Laser trimming of the chip's thin-film resistors is used to calibrate the device to 298.2 μA output at 298.2 K (25°C).

The AD590 should be used in any temperature-sensing application below 150°C in which conventional electrical temperature sensors are currently employed. The inherent low cost of a monolithic integrated circuit combined with the elimination of support circuitry makes the AD590 an attractive alternative for many temperature measurement situations. Linearization circuitry, precision voltage amplifiers, resistance measuring circuitry, and cold junction compensation are not needed in applying the AD590.

In addition to temperature measurement, applications include temperature compensation or correction of discrete components, biasing proportional to absolute temperature, flow rate measurement, level detection of fluids and anemometry. The AD590 is available in chip form, making it suitable for hybrid circuits and fast temperature measurements in protected environments.

The AD590 is particularly useful in remote sensing applications. The device is insensitive to voltage drops over long lines due to its high impedance current output. Any well-insulated twisted pair is sufficient for operation at hundreds of feet from the

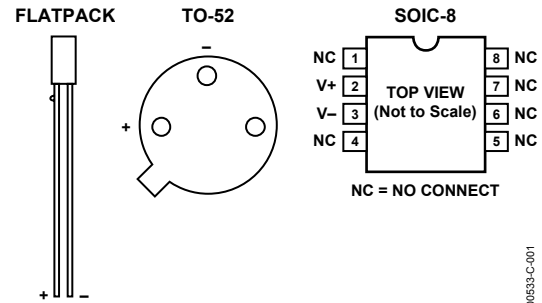

Figure 1. Pin Designations

receiving circuitry. The output characteristics also make the AD590 easy to multiplex: the current can be switched by a CMOS multiplexer or the supply voltage can be switched by a logic gate output.

PRODUCT HIGHLIGHTS

1. The AD590 is a calibrated, 2-terminal temperature sensor requiring only a dc voltage supply (4 V to 30 V). Costly transmitters, filters, lead wire compensation, and linearization circuits are all unnecessary in applying the device.
2. State-of-the-art laser trimming at the wafer level in conjunction with extensive final testing ensures that AD590 units are easily interchangeable.
3. Superior interface rejection occurs, because the output is a current rather than a voltage. In addition, power requirements are low (1.5 mWs @ 5 V @ 25°C). These features make the AD590 easy to apply as a remote sensor.
4. The high output impedance ($>10\ \text{M}\Omega$) provides excellent rejection of supply voltage drift and ripple. For instance, changing the power supply from 5 V to 10 V results in only a 1 μA maximum current change, or 1°C equivalent error.
5. The AD590 is electrically durable: it withstands a forward voltage of up to 44 V and a reverse voltage of 20 V. Therefore, supply irregularities or pin reversal does not damage the device.

Rev. C

Information furnished by Analog Devices is believed to be accurate and reliable. However, no responsibility is assumed by Analog Devices for its use, nor for any infringements of patents or other rights of third parties that may result from its use. Specifications subject to change without notice. No license is granted by implication or otherwise under any patent or patent rights of Analog Devices. Trademarks and registered trademarks are the property of their respective owners.

TABLE OF CONTENTS

| | | | |
|--|---|---|----|
| Specifications..... | 3 | Error Versus Temperature: with Calibration Error Trimmed Out..... | 7 |
| AD590J and AD590K Specifications | 3 | Error Versus Temperature: No User Trims | 7 |
| AD590L and AD590M Specifications..... | 4 | Nonlinearity | 7 |
| Absolute Maximum Ratings..... | 5 | Voltage and Thermal Environment Effects | 8 |
| ESD Caution..... | 5 | General Applications..... | 10 |
| Product Description..... | 6 | Outline Dimensions | 13 |
| Circuit Description..... | 6 | Ordering Guide | 14 |
| Explanation of Temperature Sensor Specifications | 6 | | |
| Calibration Error | 7 | | |

REVISION HISTORY

Revision C

9/03—Data Sheet Changed from REV. B to REV. C.

| | |
|---------------------------------|-----------|
| Added SOIC-8 package..... | Universal |
| Change to Figure 1..... | 1 |
| Updated OUTLINE DIMENSIONS..... | 13 |
| Added ORDERING GUIDE..... | 14 |

SPECIFICATIONS

AD590J AND AD590K SPECIFICATIONS

Table 1. @ 25°C and $V_S = 5\text{ V}$ unless otherwise noted

| Parameter | AD590J | | | AD590K | | | Unit |
|---|----------|------------------|-------------|----------|------------------|-------------|--------|
| | Min | Typ | Max | Min | Typ | Max | |
| POWER SUPPLY | | | | | | | |
| Operating Voltage Range | 4 | | 30 | 4 | | 30 | Volts |
| OUTPUT | | | | | | | |
| Nominal Current Output @ 25°C (298.2K) | | 298.2 | | | 298.2 | | μA |
| Nominal Temperature Coefficient | | 1 | | | 1 | | μA/K |
| Calibration Error @ 25°C | | | ±5.0 | | | ±2.5 | °C |
| Absolute Error (over rated performance temperature range) | | | | | | | |
| Without External Calibration Adjustment | | | ±10 | | | ±5.5 | °C |
| With 25°C Calibration Error Set to Zero | | | ±3.0 | | | ±2.0 | °C |
| Nonlinearity | | | | | | | |
| For TO-52 and Flatpack packages | | | ±1.5 | | | ±0.8 | °C |
| For 8-Lead SOIC package | | | ±1.5 | | | ±1.0 | °C |
| Repeatability ¹ | | | ±0.1 | | | ±0.1 | °C |
| Long-Term Drift ² | | | ±0.1 | | | ±0.1 | °C |
| Current Noise | | 40 | | | 40 | | pA/√Hz |
| Power Supply Rejection | | | | | | | |
| 4 V ≤ V_S ≤ 5 V | | 0.5 | | | 0.5 | | μA/V |
| 5 V ≤ V_S ≤ 15 V | | 0.2 | | | 0.2 | | μV/V |
| 15 V ≤ V_S ≤ 30 V | | 0.1 | | | 0.1 | | μA/V |
| Case Isolation to Either Lead | | 10 ¹⁰ | | | 10 ¹⁰ | | Ω |
| Effective Shunt Capacitance | | 100 | | | 100 | | pF |
| Electrical Turn-On Time | | 20 | | | 20 | | μs |
| Reverse Bias Leakage Current ³ (Reverse Voltage = 10 V) | | 10 | | | 10 | | pA |

¹ Maximum deviation between +25°C readings after temperature cycling between -55°C and +150°C; guaranteed, not tested.

² Conditions: constant 5 V, constant 125°C; guaranteed, not tested.

³ Leakage current doubles every 10°C.

Specifications shown in **boldface** are tested on all production units at final electrical test. Results from those tests are used to calculate outgoing quality levels. All min and max specifications are guaranteed, although only those shown in **boldface** are tested on all production units.

AD590

AD590L AND AD590M SPECIFICATIONS

Table 2. @ 25°C and $V_S = 5\text{ V}$ unless otherwise noted

| Parameter | AD590L | | | AD590M | | | Unit |
|---|----------|------------------|-------------|----------|------------------|-------------|--------|
| | Min | Typ | Max | Min | Typ | Max | |
| POWER SUPPLY | | | | | | | |
| Operating Voltage Range | 4 | | 30 | 4 | | 30 | Volts |
| OUTPUT | | | | | | | |
| Nominal Current Output @ 25°C (298.2K) | | 298.2 | | | 298.2 | | μA |
| Nominal Temperature Coefficient | | 1 | | | 1 | | μA/K |
| Calibration Error @ +25°C | | | ±1.0 | | | ±0.5 | °C |
| Absolute Error (over rated performance temperature range) | | | | | | | |
| Without External Calibration Adjustment | | | ±3.0 | | | ±1.7 | °C |
| With ± 25°C Calibration Error Set to Zero | | | ±1.6 | | | ±1.0 | °C |
| Nonlinearity | | | ±0.4 | | | ±0.3 | °C |
| Repeatability ¹ | | | ±0.1 | | | ±0.1 | °C |
| Long-Term Drift ² | | | ±0.1 | | | ±0.1 | °C |
| Current Noise | | 40 | | | 40 | | pA/√Hz |
| Power Supply Rejection | | | | | | | |
| 4 V ≤ V_S ≤ 5 V | | 0.5 | | | 0.5 | | μA/V |
| 5 V ≤ V_S ≤ 15 V | | 0.2 | | | 0.2 | | μA/V |
| 15 V ≤ V_S ≤ 30 V | | 0.1 | | | 0.1 | | μA/V |
| Case Isolation to Either Lead | | 10 ¹⁰ | | | 10 ¹⁰ | | Ω |
| Effective Shunt Capacitance | | 100 | | | 100 | | pF |
| Electrical Turn-On Time | | 20 | | | 20 | | μs |
| Reverse Bias Leakage Current ³ (Reverse Voltage = 10 V) | | 10 | | | 10 | | pA |

¹ Maximum deviation between +25°C readings after temperature cycling between -55°C and +150°C; guaranteed, not tested.

² Conditions: constant 5 V, constant 125°C; guaranteed, not tested.

³ Leakage current doubles every 10°C.

Specifications shown in **boldface** are tested on all production units at final electrical test. Results from those tests are used to calculate outgoing quality levels. All min and max specifications are guaranteed, although only those shown in **boldface** are tested on all production units.

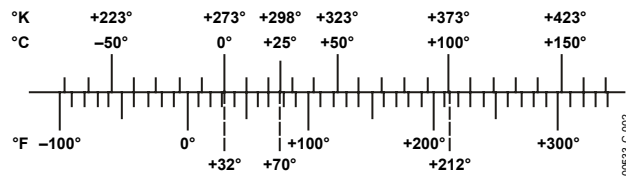

$$^{\circ}\text{C} = \frac{5}{9} (^{\circ}\text{F} - 32) \quad \text{K} = ^{\circ}\text{C} + 273.15$$

$$^{\circ}\text{F} = \frac{9}{5} (^{\circ}\text{C} + 32) \quad ^{\circ}\text{R} = ^{\circ}\text{F} + 459.7$$

Figure 2. Temperature Scale Conversion Equations

ABSOLUTE MAXIMUM RATINGS

Table 3.

| Parameter | Rating |
|--|-----------------|
| Forward Voltage (E+ or E-) | 44 V |
| Reverse Voltage (E+ to E-) | -20 V |
| Breakdown Voltage (Case E+ or E-) | ±200 V |
| Rated Performance Temperature Range ¹ | -55°C to +150°C |
| Storage Temperature Range ¹ | -65°C to +155°C |
| Lead Temperature (Soldering, 10 sec) | 300°C |

Stresses above those listed under Absolute Maximum Ratings may cause permanent damage to the device. This is a stress rating only and functional operation of the device at these or any other conditions above those indicated in the operational section of this specification is not implied. Exposure to absolute maximum rating conditions for extended periods may affect device reliability.

¹The AD590 has been used at -100°C and +200°C for short periods of measurement with no physical damage to the device. However, the absolute errors specified apply to only the rated performance temperature range.

ESD CAUTION

ESD (electrostatic discharge) sensitive device. Electrostatic charges as high as 4000 V readily accumulate on the human body and test equipment and can discharge without detection. Although this product features proprietary ESD protection circuitry, permanent damage may occur on devices subjected to high energy electrostatic discharges. Therefore, proper ESD precautions are recommended to avoid performance degradation or loss of functionality.



PRODUCT DESCRIPTION

The AD590H has 60 μ inches of gold plating on its Kovar leads and Kovar header. A resistance welder is used to seal the nickel cap to the header. The AD590 chip is eutectically mounted to the header and ultrasonically bonded to with 1 mil aluminum wire. Kovar composition: 53% iron nominal; 29% ±1% nickel; 17% ±1% cobalt; 0.65% manganese max; 0.20% silicon max; 0.10% aluminum max; 0.10% magnesium max; 0.10% zirconium max; 0.10% titanium max; 0.06% carbon max.

The AD590F is a ceramic package with gold plating on its Kovar leads, Kovar lid, and chip cavity. Solder of 80/20 Au/Sn composition is used for the 1.5 mil thick solder ring under the lid. The chip cavity has a nickel underlay between the metallization and the gold plating. The AD590 chip is eutectically mounted in the chip cavity at 410°C and ultrasonically bonded to with 1 mil aluminum wire. Note that the chip is in direct contact with the ceramic base, not the metal lid. When using the AD590 in die form, the chip substrate must be kept electrically isolated (floating) for correct circuit operation.

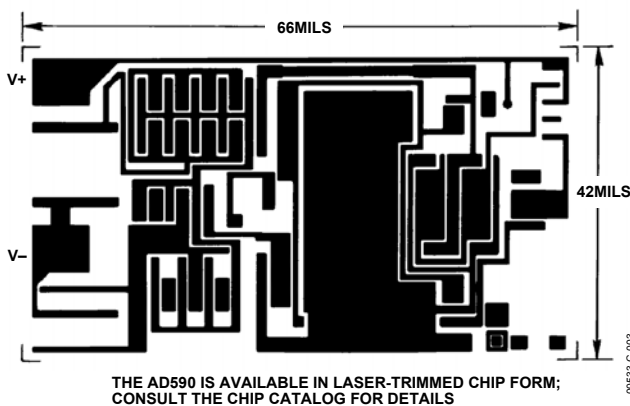

Figure 3. Metalization Diagram

CIRCUIT DESCRIPTION¹

The AD590 uses a fundamental property of the silicon transistors from which it is made to realize its temperature proportional characteristic: if two identical transistors are operated at a constant ratio of collector current densities, r , then the difference in their base-emitter voltage will be $(kT/q)(\ln r)$. Since both k (Boltzman's constant) and q (the charge of an electron) are constant, the resulting voltage is directly proportional to absolute temperature (PTAT).

In the AD590, this PTAT voltage is converted to a PTAT current by low temperature coefficient thin-film resistors. The total current of the device is then forced to be a multiple of this

PTAT current. Figure 4 is the schematic diagram of the AD590. In this figure, Q8 and Q11 are the transistors that produce the PTAT voltage. R5 and R6 convert the voltage to current. Q10, whose collector current tracks the collector currents in Q9 and Q11, supplies all the bias and substrate leakage current for the rest of the circuit, forcing the total current to be PTAT. R5 and R6 are laser-trimmed on the wafer to calibrate the device at 25°C.

Figure 5 shows the typical V-I characteristic of the circuit at 25°C and the temperature extremes.

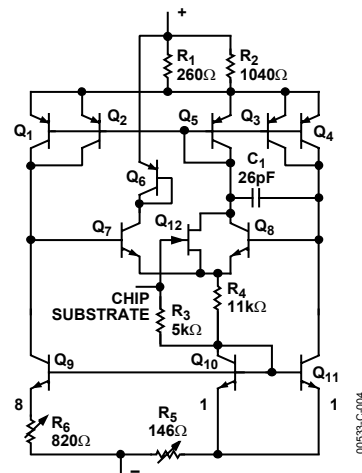

Figure 4. Schematic Diagram

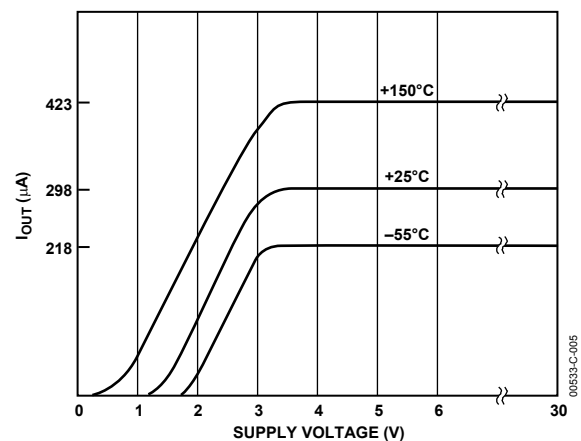

Figure 5. V-I Plot

EXPLANATION OF TEMPERATURE SENSOR SPECIFICATIONS

The way in which the AD590 is specified makes it easy to apply in a wide variety of applications. It is important to understand the meaning of the various specifications and the effects of supply voltage and thermal environment on accuracy.

¹ For a more detailed description, see M.P. Timko, "A Two-Terminal IC Temperature Transducer," IEEE J. Solid State Circuits, Vol. SC-11, p. 784-788, Dec. 1976. Understanding the Specifications-AD590.

The AD590 is basically a PTAT (proportional to absolute temperature)¹ current regulator. That is, the output current is equal to a scale factor times the temperature of the sensor in degrees Kelvin. This scale factor is trimmed to 1 $\mu\text{A}/\text{K}$ at the factory, by adjusting the indicated temperature (that is, the output current) to agree with the actual temperature. This is done with 5 V across the device at a temperature within a few degrees of 25°C (298.2K). The device is then packaged and tested for accuracy over temperature.

CALIBRATION ERROR

At final factory test, the difference between the indicated temperature and the actual temperature is called the calibration error. Since this is a scale factory error, its contribution to the total error of the device is PTAT. For example, the effect of the 1°C specified maximum error of the AD590L varies from 0.73°C at -55°C to 1.42°C at 150°C. Figure 6 shows how an exaggerated calibration error would vary from the ideal over temperature.

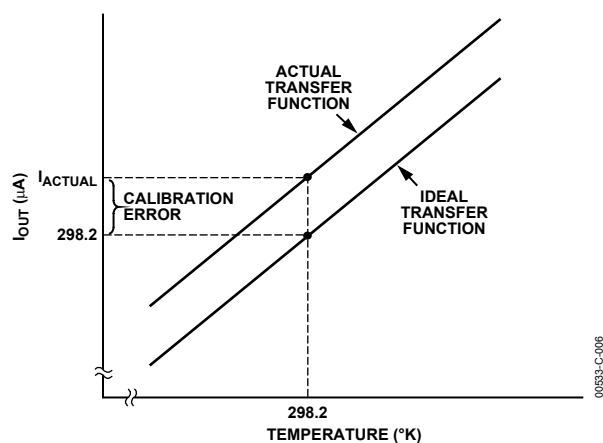

Figure 6. Calibration Error vs. Temperature

The calibration error is a primary contributor to maximum total error in all AD590 grades. However, since it is a scale factor error, it is particularly easy to trim. Figure 7 shows the most elementary way of accomplishing this. To trim this circuit, the temperature of the AD590 is measured by a reference temperature sensor and R is trimmed so that $V_T = 1 \text{ mV}/\text{K}$ at that temperature. Note that when this error is trimmed out at one temperature, its effect is zero over the entire temperature range. In most applications there is a current-to-voltage conversion resistor (or, as with a current input ADC, a reference) that can be trimmed for scale factor adjustment.

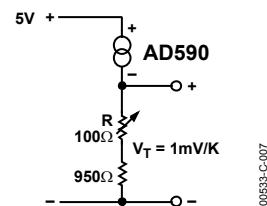

Figure 7. One Temperature Trim

ERROR VERSUS TEMPERATURE: WITH CALIBRATION ERROR TRIMMED OUT

Each AD590 is tested for error over the temperature range with the calibration error trimmed out. This specification could also be called the “variance from PTAT,” because it is the maximum difference between the actual current over temperature and a PTAT multiplication of the actual current at 25°C. This error consists of a slope error and some curvature, mostly at the temperature extremes. Figure 8 shows a typical AD590K temperature curve before and after calibration error trimming.

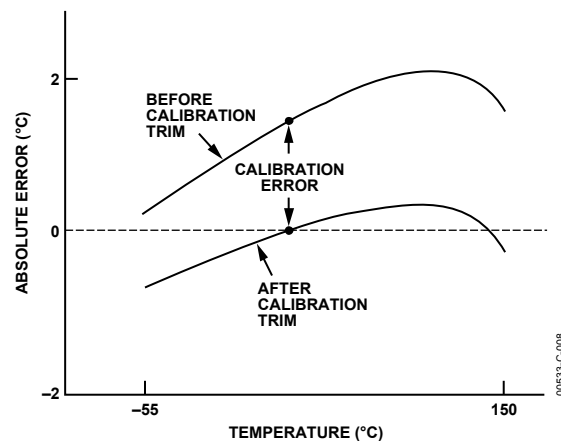

Figure 8. Effect to Scale Factor Trim on Accuracy

ERROR VERSUS TEMPERATURE: NO USER TRIMS

Using the AD590 by simply measuring the current, the total error is the variance from PTAT, described above, plus the effect of the calibration error over temperature. For example, the AD590L maximum total error varies from 2.33°C at -55°C to 3.02°C at 150°C. For simplicity, only the large figure is shown on the specification page.

NONLINEARITY

Nonlinearity as it applies to the AD590 is the maximum deviation of current over temperature from a best-fit straight line. The nonlinearity of the AD590 over the -55°C to +150°C range is superior to all conventional electrical temperature sensors such as thermocouples, RTDs, and thermistors. Figure 9 shows the nonlinearity of the typical AD590K from Figure 8.

¹ $T(^{\circ}\text{C}) = T(\text{K}) - 273.2$. Zero on the Kelvin scale is “absolute zero”; there is no lower temperature.

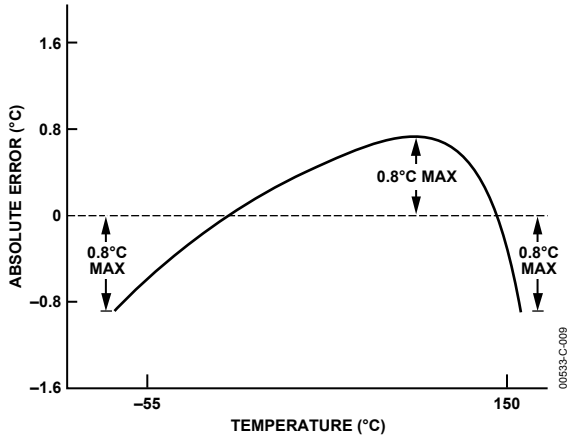

Figure 9. Nonlinearity

Figure 10 shows a circuit in which the nonlinearity is the major contributor to error over temperature. The circuit is trimmed by adjusting R1 for a 0 V output with the AD590 at 0°C. R2 is then adjusted for 10 V out with the sensor at 100°C. Other pairs of temperatures may be used with this procedure as long as they are measured accurately by a reference sensor. Note that for 15 V output (150°C) the V+ of the op amp must be greater than 17 V. Also note that V- should be at least -4 V; if V- is ground, there is no voltage applied across the device.

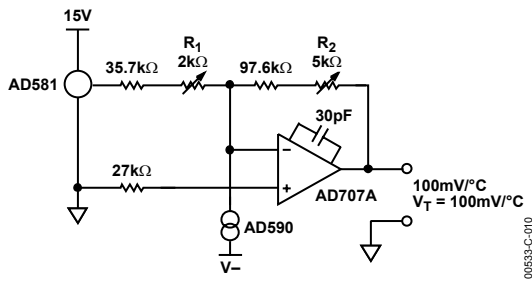

Figure 10. 2-Temperature Trim

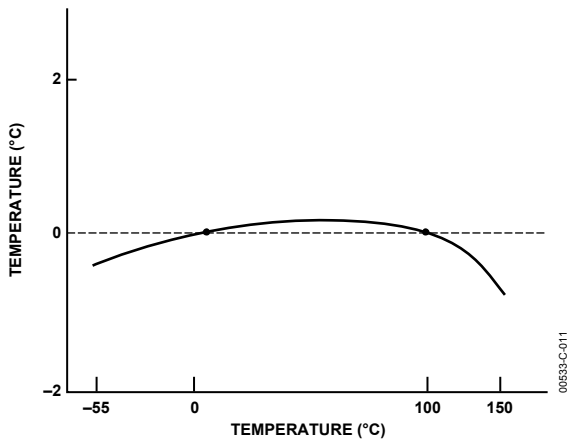

Figure 11. Typical 2-Trim Accuracy

VOLTAGE AND THERMAL ENVIRONMENT EFFECTS

The power supply rejection specifications show the maximum expected change in output current versus input voltage changes. The insensitivity of the output to input voltage allows the use of unregulated supplies. It also means that hundreds of ohms of resistance (such as a CMOS multiplexer) can be tolerated in series with the device.

It is important to note that using a supply voltage other than 5 V does not change the PTAT nature of the AD590. In other words, this change is equivalent to a calibration error and can be removed by the scale factor trim (see Figure 8).

The AD590 specifications are guaranteed for use in a low thermal resistance environment with 5 V across the sensor. Large changes in the thermal resistance of the sensor's environment change the amount of self-heating and result in changes in the output, which are predictable but not necessarily desirable.

The thermal environment in which the AD590 is used determines two important characteristics: the effect of self-heating and the response of the sensor with time. Figure 12 is a model of the AD590 that demonstrates these characteristics.

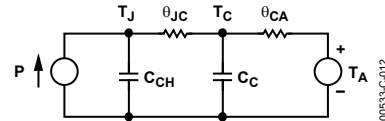

Figure 12. Thermal Circuit Model

As an example, for the TO-52 package, θ_{JC} is the thermal resistance between the chip and the case, about 26°C/W. θ_{CA} is the thermal resistance between the case and the surroundings and is determined by the characteristics of the thermal connection. Power source P represents the power dissipated on the chip. The rise of the junction temperature, T_J , above the ambient temperature T_A is

$$T_J - T_A = P(\theta_{JC} + \theta_{CA})$$

Equation 1.

Table 4 gives the sum of θ_{JC} and θ_{CA} for several common thermal media for both the H and F packages. The heat sink used was a common clip-on. Using Equation 1, the temperature rise of an AD590 H package in a stirred bath at 25°C, when driven with a 5 V supply, is 0.06°C. However, for the same conditions in still air, the temperature rise is 0.72°C. For a given supply voltage, the temperature rise varies with the current and is PTAT. Therefore, if an application circuit is trimmed with the sensor in the same thermal environment in which it will be used, the scale factor trim compensates for this effect over the entire temperature range.

Table 4. Thermal Resistance

| Medium | $\theta_{JC} + \theta_{CA}$ (°C/Watt) | | τ (sec) ¹ | |
|--------------------------|---------------------------------------|-----|---------------------------|------|
| | H | F | H | F |
| Aluminum Block | 30 | 10 | 0.6 | 0.1 |
| Stirred Oil ² | 42 | 60 | 1.4 | 0.6 |
| Moving Air ³ | | | | |
| With Heat Sink | 45 | – | 5.0 | – |
| Without Heat Sink | 115 | 190 | 13.5 | 10.0 |
| Still Air | | | | |
| With Heat Sink | 191 | – | 108 | – |
| Without Heat Sink | 480 | 650 | 60 | 30 |

¹ τ is dependent upon velocity of oil; average of several velocities listed above.

²Air velocity @ 9 ft/sec.

³The time constant is defined as the time required to reach 63.2% of an instantaneous temperature change.

The time response of the AD590 to a step change in temperature is determined by the thermal resistances and the thermal capacities of the chip, C_{CH} , and the case, C_C . C_{CH} is about 0.04 Ws/°C for the AD590. C_C varies with the measured medium, because it includes anything that is in direct thermal contact with the case. The single time constant exponential curve of Figure 13 is usually sufficient to describe the time

response, $T(t)$. Table 4 shows the effective time constant, τ , for several media.

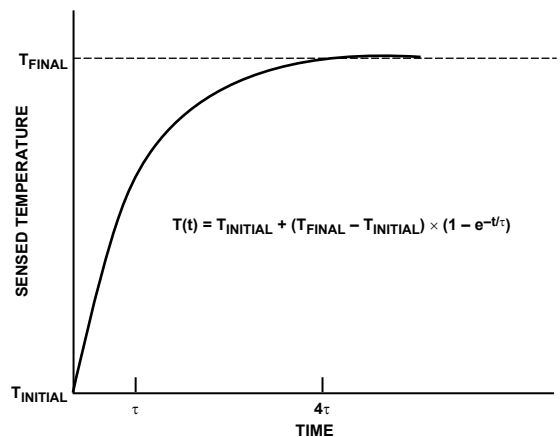

Figure 13. Time Response Curve

GENERAL APPLICATIONS

Figure 14 demonstrates the use of a low cost digital panel meter for the display of temperature on either the Kelvin, Celsius, or Fahrenheit scales. For Kelvin temperature, Pins 9, 4, and 2 are grounded; for Fahrenheit temperature, Pins 4 and 2 are left open.

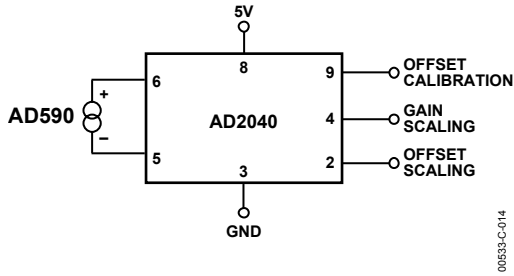

Figure 14. Variable Scale Display

The above configuration yields a 3-digit display with 1°C or 1°F resolution, in addition to an absolute accuracy of ±2.0°C over the -55°C to +125°C temperature range, if a one-temperature calibration is performed on an AD590K, AD590L, or AD590M.

Connecting several AD590 units in series as shown in Figure 15 allows the minimum of all the sensed temperatures to be indicated. In contrast, using the sensors in parallel yields the average of the sensed temperatures.

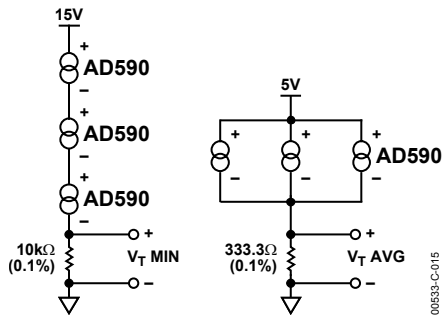

Figure 15. Series and Parallel Connection

The circuit in Figure 16 demonstrates one method by which differential temperature measurements can be made. R1 and R2 can be used to trim the output of the op amp to indicate a desired temperature difference. For example, the inherent offset between the two devices can be trimmed in. If V+ and V- are radically different, then the difference in internal dissipation causes a differential internal temperature rise. This effect can be used to measure the ambient thermal resistance seen by the sensors in applications such as fluid-level detectors or anemometry.

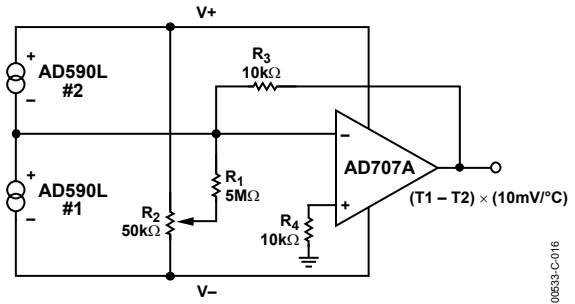

Figure 16. Differential Measurements

Figure 17 is an example of a cold junction compensation circuit for a Type J thermocouple using the AD590 to monitor the reference junction temperature. This circuit replaces an ice-bath as the thermocouple reference for ambient temperatures between 15°C and 35°C. The circuit is calibrated by adjusting R_T for a proper meter reading with the measuring junction at a known reference temperature and the circuit near 25°C. Using components with the TCs as specified in Figure 17, compensation accuracy is within ±0.5°C for circuit temperatures between 15°C and 35°C. Other thermocouple types can be accommodated with different resistor values. Note that the TCs of the voltage reference and the resistors are the primary contributors to error.

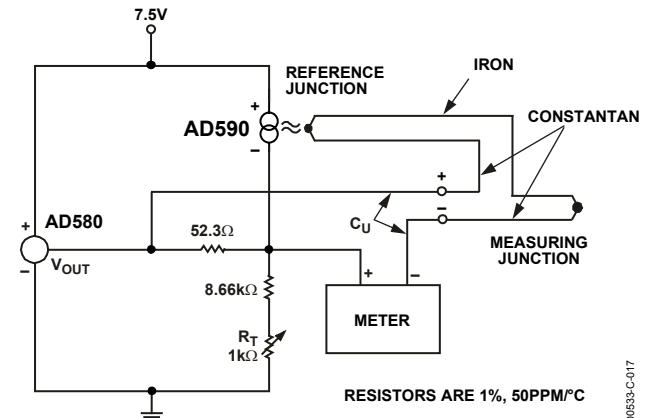

Figure 17. Cold Junction Compensation Circuit for Type J Thermocouple

Figure 18 is an example of a current transmitter designed to be used with 40 V, 1 kΩ systems; it uses its full current range of 4 mA to 20 mA for a narrow span of measured temperatures. In this example, the 1 μA/K output of the AD590 is amplified to 1 mA/°C and offset so that 4 mA is equivalent to 17°C and 20 mA is equivalent to 33°C. R_T is trimmed for proper reading at an intermediate reference temperature. With a suitable choice of resistors, any temperature range within the operating limits of the AD590 may be chosen.

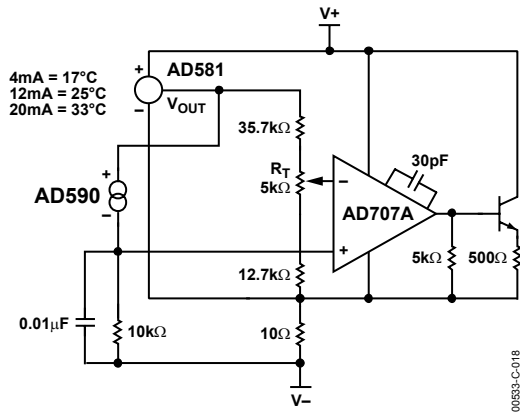

Figure 18. 4 mA to 20 mA Current Transmitter

Figure 19 is an example of a variable temperature control circuit (thermostat) using the AD590. R_H and R_L are selected to set the high and low limits for R_{SET} . R_{SET} could be a simple pot, a calibrated multiturn pot, or a switched resistive divider. Powering the AD590 from the 10 V reference isolates the AD590 from supply variations while maintaining a reasonable voltage (~ 7 V) across it. Capacitor C_1 is often needed to filter extraneous noise from remote sensors. R_B is determined by the β of the power transistor and the current requirements of the load.

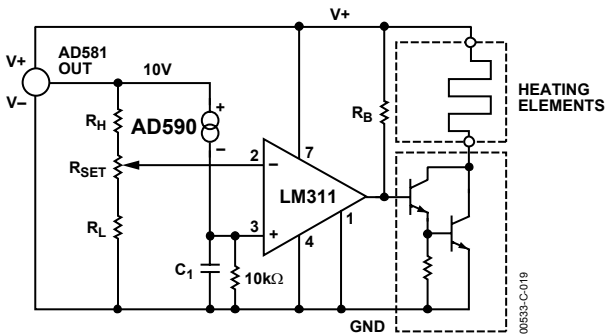

Figure 19. Simple Temperature Control Circuit

Figure 20 shows that the AD590 can be configured with an 8-bit DAC to produce a digitally controlled set point. This particular circuit operates from 0°C (all inputs high) to 51.0°C (all inputs low) in 0.2°C steps. The comparator is shown with 1.0°C hysteresis, which is usually necessary to guard-band for extraneous noise. Omitting the 5.1 MΩ resistor results in no hysteresis.

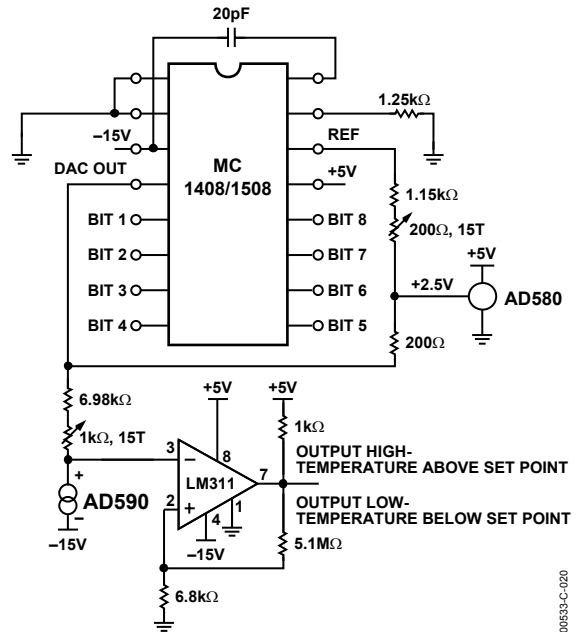

Figure 20. DAC Set Point

The voltage compliance and the reverse blocking characteristic of the AD590 allows it to be powered directly from 5 V CMOS logic. This permits easy multiplexing, switching, or pulsing for minimum internal heat dissipation. In Figure 21, any AD590 connected to a logic high passes a signal current through the current measuring circuitry, while those connected to a logic zero pass insignificant current. The outputs used to drive the AD590s may be employed for other purposes, but the additional capacitance due to the AD590 should be taken into account.

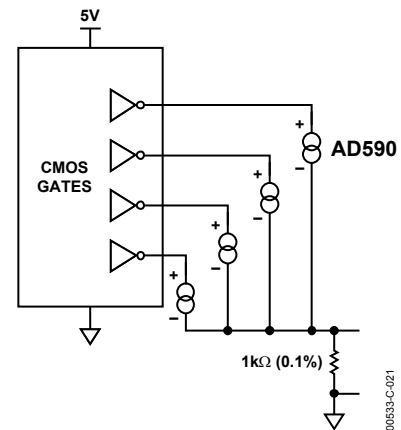

Figure 21. AD590 Driven from CMOS Logic

CMOS analog multiplexers can also be used to switch AD590 current. Due to the AD590's current mode, the resistance of such switches is unimportant as long as 4 V is maintained across the transducer. Figure 22 shows a circuit that combines the principle demonstrated in Figure 21 with an 8-channel CMOS multiplexer. The resulting circuit can select 1–80 sensors over only 18 wires with a 7-bit binary word.

AD590

The inhibit input on the multiplexer turns all sensors off for minimum dissipation while idling.

Figure 23 demonstrates a method of multiplexing the AD590 in the two-trim mode (see Figure 10 and Figure 11). Additional AD590s and their associated resistors can be added to multiplex

up to eight channels of $\pm 0.5^\circ\text{C}$ absolute accuracy over the temperature range of -55°C to $+125^\circ\text{C}$. The high temperature restriction of 125°C is due to the output range of the op amps; output to 150°C can be achieved by using a 20 V supply for the op amp.

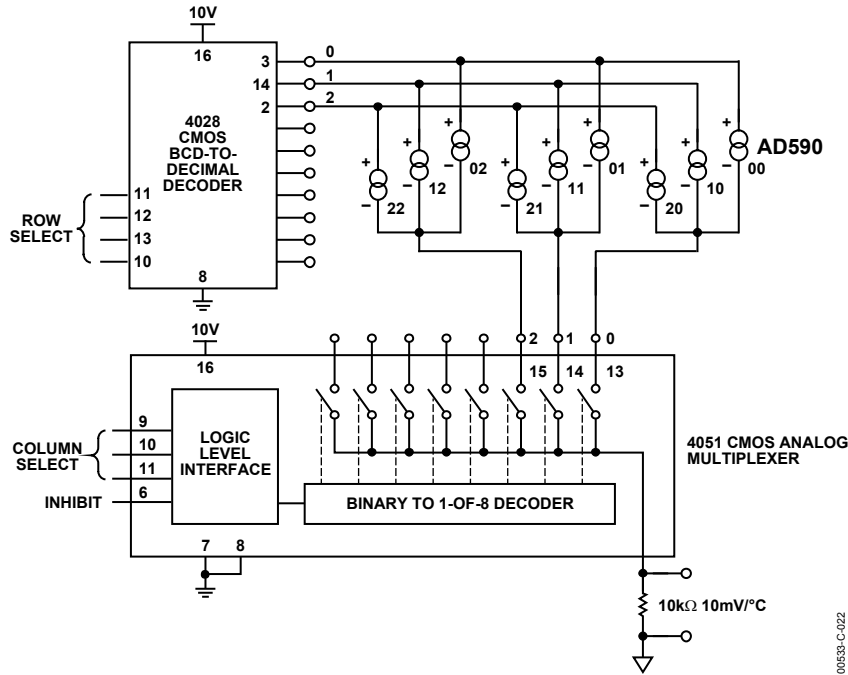

Figure 22. Matrix Multiplexer

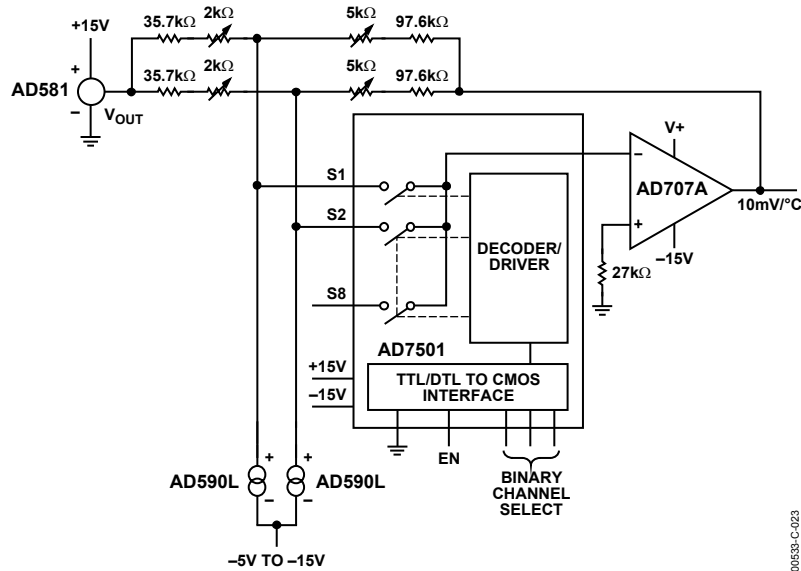

Figure 23. 8-Channel Multiplexer

OUTLINE DIMENSIONS

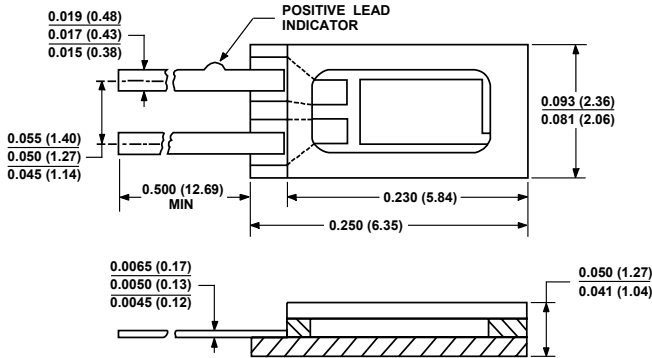
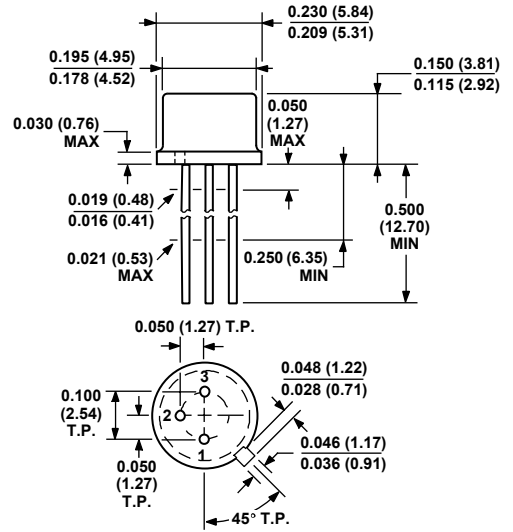
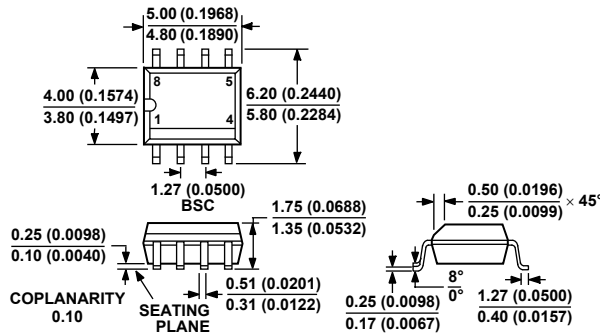

Figure 24. 2-Lead Ceramic Flat Package [CQFP] (F-2)
Dimensions shown in inches and (millimeters)



CONTROLLING DIMENSIONS ARE IN INCHES; MILLIMETERS DIMENSIONS (IN PARENTHESES) ARE ROUNDED-OFF INCH EQUIVALENTS FOR REFERENCE ONLY AND ARE NOT APPROPRIATE FOR USE IN DESIGN

Figure 25. 3-Pin Metal Header Package [TO-52] (H-03)
Dimensions shown in inches and (millimeters)



COMPLIANT TO JEDEC STANDARDS MS-012AA
CONTROLLING DIMENSIONS ARE IN MILLIMETERS; INCH DIMENSIONS (IN PARENTHESES) ARE ROUNDED-OFF MILLIMETER EQUIVALENTS FOR REFERENCE ONLY AND ARE NOT APPROPRIATE FOR USE IN DESIGN

Figure 26. 8-Lead Standard Small Outline Package [SOIC] Narrow Body (R-8)
Dimensions shown in millimeters and (inches)

AD590

ORDERING GUIDE

| Model | Temperature Range | Package Description | Package Option |
|----------------------|-------------------|---------------------|----------------|
| AD590JH ¹ | –55°C to +150°C | TO-52 | H-03A |
| AD590JF ¹ | –55°C to +150°C | Flatpack | F-2A |
| AD590JR | –55°C to +150°C | 8-Lead SOIC | SOIC-8 |
| AD590KH ¹ | –55°C to +150°C | TO-52 | H-03A |
| AD590KF ¹ | –55°C to +150°C | Flatpack | F-2A |
| AD590KR | –55°C to +150°C | 8-Lead SOIC | SOIC-8 |
| AD590LH ¹ | –55°C to +150°C | TO-52 | H-03A |
| AD590LF ¹ | –55°C to +150°C | Flatpack | F-2A |
| AD590MH ¹ | –55°C to +150°C | TO-52 | H-03A |
| AD590MF ¹ | –55°C to +150°C | Flatpack | F-2A |
| AD590JR-REEL | –55°C to +150°C | 8-Lead SOIC | SOIC-8 |
| AD590KR-REEL | –55°C to +150°C | 8-Lead SOIC | SOIC-8 |
| AD590JCHIPS | –55°C to +150°C | TO-52 | H-03A |

¹Available in 883B; consult factory for data sheet.

NOTES

AD590

NOTES